

Capacity: 2" through 8"

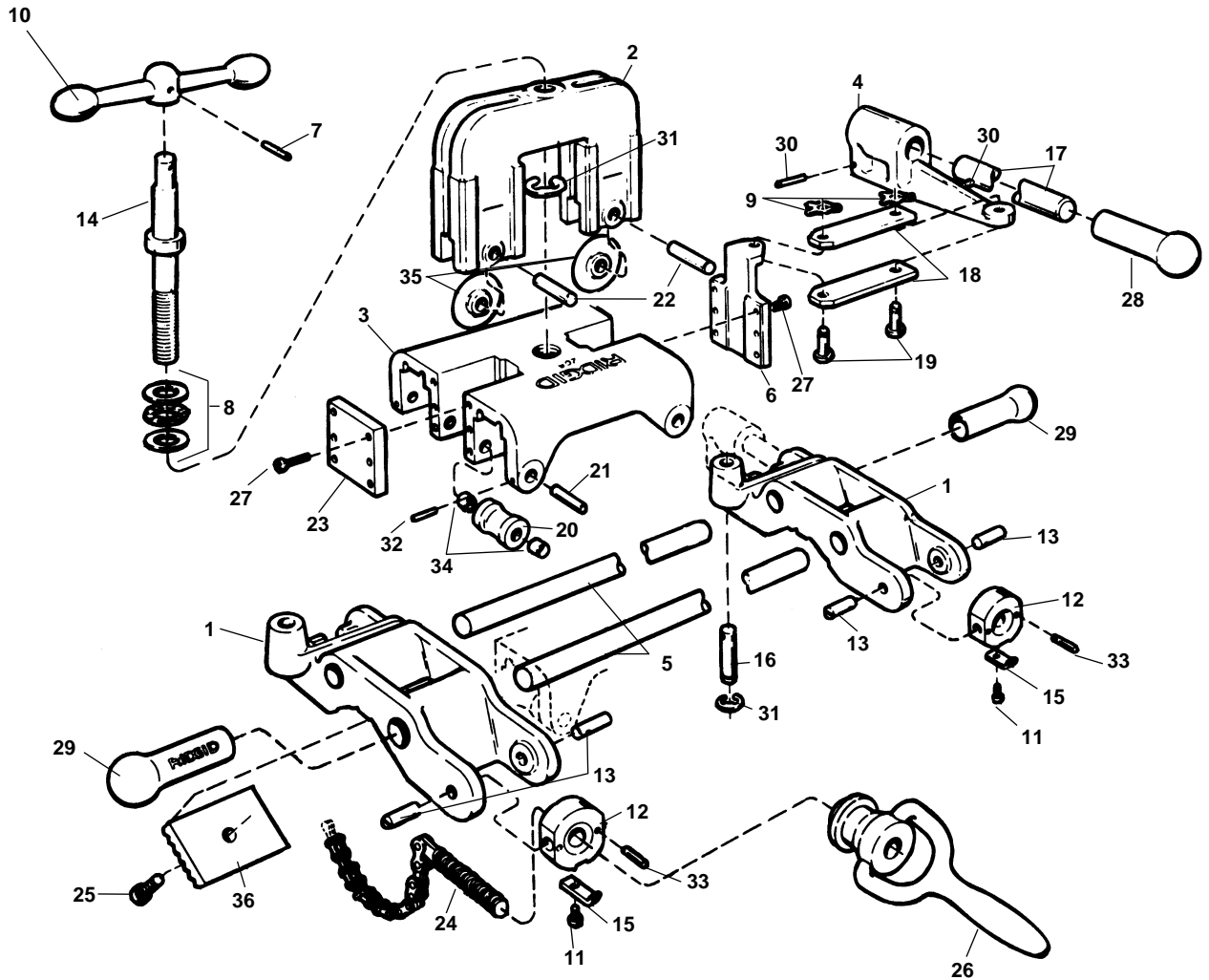

**NOTE: Order parts by Catalog Number only.
DO NOT order by Reference Number.**

Ref. No.	Catalog No.	Description	Ref. No.	Catalog No.	Description
—	32860	208 Axial Pipe Cutter	19	34045	Link Pin (2)
1	33330	Support (2)	20	34050	Roll (4)
2	33335	Yoke	21	34055	Roll Pin (4)
3	33340	Carriage	22	34060	Cutter Wheel Pin (2)
4	33460	Pivot Arm	23	34065	Plate
5	33465	Support Bar (2)	24	34070	Chain and Screw Assembly
6	33470	Angle Plate	25	34075	Screw (4)
7	47160	Feed Screw Crank Pin	26	40765	Handle and Nut Assembly (2)
8	41425	Thrust Bearing	27	40910	Screw (12)
9	45180	"X" Washer (2)	28	51570	Handgrip
10	45765	Feed Screw Crank	29	51735	Handgrip (2)
11	32145	Screw (2)	30	74965	Roll Pin (2)
12	34010	Pivot Block (2)	31	58850	"E" Ring (2)
13	34015	Pivot Block Pin (4)	32	41500	Roll Pin (4)
14	34020	Feed Screw	33	41545	Roll Pin (4)
15	34025	Nut Retainer (2)	34	41550	Needle Bearing (8)
16	34030	Pivot Arm Pin	35	33145	Cutter Wheel (2)
17	34035	Handle	36	40660	Jaw (4) (2 per Set)
18	34040	Link (2)			